



**AKSA Power Generation** has been producing industrial generator sets with an innovative compact design and excellence in quality for over 30 years. AKSA has been providing reliable power through three main production plants and over 15 branch offices worldwide.

**General Characteristics**

Model Name	APD-NG200
Engine Make	PSI
Engine Model	11L Turbo
Alternator Make	Stamford
Control Panel Make & Model	DSE 7320
Frequency & Speed	60Hz, 1800rpm
Enclosure Make & Model	AKSA AUL 61/62



**Genset Rating**

Engine	Alternator	Voltage	PF	NG Standby Power	NG Standby Current	LP Gas Standby Power	LP Gas Standby Current
11L Turbo	UCDI274K (Wnd-311)	480/277V	0.8	200kW	301A	135kW	203A
	UCDI274K (Wnd-311)	240/120V	0.8	200kW	601A	135kW	406A
	UCDI274K (Wnd-311)	208/120V	0.8	200kW	694A	135kW	468A
	UCI274H (Wnd-17)	600/347V	0.8	200kW	241A	135kW	162A

**\*EPA – Certified for Emergency Stationary Applications**

Stand-by Power (Maximum): Power available at variable load in the event of main power network failure. No over load is permitted.  
 Prime Power: Power available at variable load in lieu of a main power network. Overload of 10% is permitted for 1 hour in every 12 hours of operation.  
 The above ratings represent the engine performance capabilities to conditions specified in accordance with ISO 8528/5 & ISO3046.  
**Derating may be required for conditions outside of the test conditions.**

**Codes & Standards**

The Generator set is designed and manufactured in a facility certified to **ISO9001** standards.

The Generator set is designed and manufactured in a facility certified to **ISO14001:2015** standards.

**AKSA Power Generation** provides **single source responsibility** for the generator set & accessories.

The generator set, with its components, are **prototype tested** and **production tested** according to the UL test program.

The generator set meets **NFPA70, 99, 110, 37** Level 1 when equipped with the necessary accessories and installed per NFPA standards.



\*Manufacturer reserves the right to make changes in model, technical specifications, color, equipment and accessories without prior notice.



### Engine Data

Manufacturer	PSI
Model	11L Turbo
Displacement & Cylinders	11.1 L / 6 Cylinders
Engine Type	In-line, 4 Cycle
Engine Speed	1800rpm
Engine Standby Power NG	235kW
Engine Standby Power LP	155 kW
Aspiration	Turbo Charge Air Cooled
Compression Ratio	10.5 : 1
Bore / Stroke	123 mm / 155 mm
Governor type	Electronic

### Fuel System

Fuel Type	NG, LP Gas/Dual Fuel
Min NG Supply pipe size	2" NPTF
Maximum EPR Rated Pressure	7 kPa / 1.0 psi
Recommended Max Pressure	2.7 kPa / 11 inH2O
Recommended Min Pressure	1.7 kPa / 7 inH2O

### Fuel Consumption

	Natural Gas	LP Gas
Standby Power (100%)	2432 cfh 69 m <sup>3</sup> /hr	20 gal/hr 75 liters/hr

### Electric System

System Voltage (dc)	24V
Battery Qty, Rating	2 x 120Ah

### Cooling System

Radiator Cooling System Type	Closed Circuit
Coolant Capacity	23 gal
Cranking Temperature	160 °F
Full Open Temperature	185 °F

### Exhaust System

Type	Water cooled manifold
Max. allowable back pressure	10.2 kPa
Max Turbine Outlet Temperature	1220 °F
Exhaust Gas Flow at Turbine Outlet Conditions	1326 cfm

### Air Intake System

Combustion Air Required	415 cfm
Max Intake Air Restriction (Clean Element)	1.2 kPa / 4.8 inH2O
Air Filter Type	Dry Paper Element

### Lubrication System

Oil Specifications	SAE 15W-40 Low Ash Gas Ash content 0.25 - 0.5% by weight
Oil Pan Capacity, Min-Max	20 - 26 Qts
Oil filter; qt, type	1, Cartridge
Min – Max Oil Pressure at Rated Speed	20 psi – 70 psi



### Alternator Data

Manufacturer	Stamford
Standards	BS EN 60034
Control System	PMG
A.V.R.	MX341
Voltage Regulation	± 1 %
Insulation System	Class H
Protection	IP23
Rated Power Factor	0.8
Stator Winding	Double Layer Concentric
Winding Pitch	Two Thirds
Winding Leads	12
Telephone Interference	THF < 2 %
Waveform Distortion	No Load < 1.5 %
Maximum Over speed	2250 rev/min

### Battery Charger & Electrical System Data

Manufacturer	ComAp
Model	InteliCharger
Input Voltage	85V ~ 264V AC
Output Voltage / Current	13.8V Float / 4A pk

### Jacket Water Heater Data

Manufacturer	Hotstart
Model	CTM15210-N00
Input Voltage	240V
Power	1500W

### Controller Data

Manufacturer	DSE
Model	7320 MK II

### Controller Features & Benefits

- Microprocessor controlled, UL & NFPA110 Compatible
- License free PC Software (Non-proprietary Software)
- IP65 rating offers increased resistance to water ingress
- Modules can be integrated to building management systems
- Real time clock provides accurate event log
- Four line back-lit LCD text display
- Five key menu navigation, two wire start/stop at Auto mode
- Front panel editing with PIN protection
- Support up to three remote display modules
- Configurable timers and alarms
- Multiple date and timer scheduler
- Integral PLC editor
- 'Protections disabled' feature
- Load switching (load shedding and dummy load outputs)
- Fully configurable via DSE Configuration Suite PC Software
- SCADA monitoring via DSE Configuration Suite PC Software

### Protection

- ✓ Gen. Voltage – under / over
- ✓ Gen. Freq. – under / over
- ✓ Engine Speed – under / over
- ✓ Engine Oil Pressure – low
- ✓ Engine Temp – low / high
- ✓ Battery Voltage – low / high
- ✓ Weak Battery
- ✓ Fail to Start / Stop
- ✓ Charge Alternator Fail
- ✓ Over Current & Load (kW/kVAr)
- ✓ Unbalanced Load
- ✓ Independent Earth Fault
- ✓ Reverse Power
- ✓ Loss of Speed Signal

### Instruments

- ✓ Gen. Voltage (L-L/L-N)
- ✓ Gen. Frequency
- ✓ Engine speed
- ✓ Oil Pressure
- ✓ Water Temperature
- ✓ Battery Voltage
- ✓ Run Time
- ✓ Phase Sequence
- ✓ Power monitoring (kWh/kVAh/kVArh)
- ✓ Power (kWh/kVAh/kVArh)
- ✓ Power Factor
- ✓ Generator Current
- ✓ Generator Load (%)
- ✓ Earth Current



**Enclosure Features**

- ✓ Heavy Duty Steel / Aluminum Structure
- ✓ E-Stop on Enclosure
- ✓ Control Panel Eliminated from Engine Vibrations
- ✓ Standard Sound Attenuation Foam
- ✓ Plastic Covered Corrosion Resistant Locks & Hinges

**Enclosure Features**

- ✓ Internally Mounted Exhaust System with Rain Cap
- ✓ Coolant Fill Cap
- ✓ Removable Base Frame Lifting Hooks
- ✓ Oil & Coolant Drain Ports
- ✓ Easy Access for Maintenance

**Open Skid Gen-Set Dimensions**

Length	126 in
Width w/o lift hooks	55 in
Height	78 in
Dry Weight	6500 lb

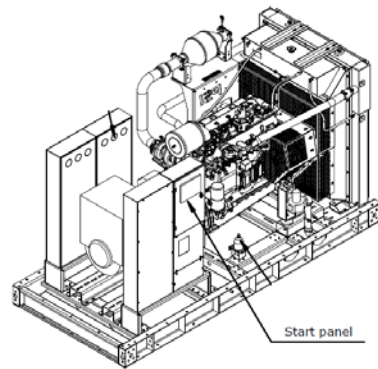

**Enclosed Gen-Set Dimensions – Level 1**

Length	162 in
Width w/o lift hooks	55 in
Height	87 in
Dry Weight	8500 lb
Sound Pressure @ 7 meters	76 dBA

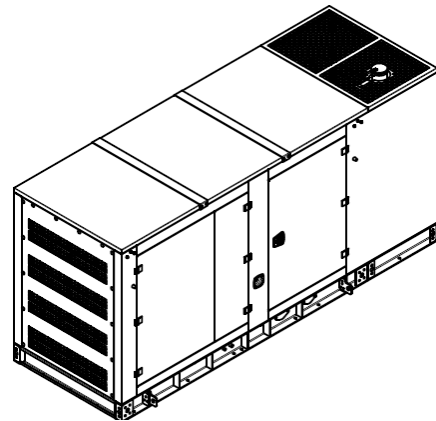

**Enclosed Gen-Set Dimensions – Level 2**

Length	162 in
Width w/o lift hooks	55 in
Height	108.4 in
Dry Weight	8950 lb
Sound Pressure @ 7 meters	72 dBA

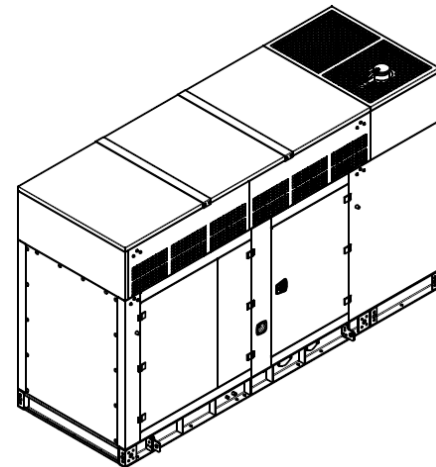

\*Manufacturer reserves the right to make changes in model, technical specifications, color, equipment and accessories without prior notice.

**Standard Features & Accessories**

- ✓ UL2200 Certification
- ✓ Heavy Duty Steel Base Frame
- ✓ PMG
- ✓ Engine Jacket Water Heater
- ✓ Battery and Battery Rack
- ✓ Battery Charger
- ✓ Anti Vibration Pads between Engine/Alternator & Base Frame
- ✓ Critical Grade Silencer Inside Enclosure
- ✓ Residential Grade Silencer Set for Open Skid Sets
- ✓ Exhaust outlet rain cap and radiator fill cap
- ✓ Sound Absorb Foam Material for Enclosure
- ✓ Emergency Stop Button
- ✓ Oil Drain Valve
- ✓ Coolant Drain Valve
- ✓ Jacket Water Heater Isolation Valves
- ✓ Flex Fuel Lines
- ✓ Secondary Lock-off Valve on Baseframe
- ✓ Engine Manifold Cover
- ✓ Turbocharger Cover
- ✓ Protection Covers for Rotating Parts
- ✓ Exhaust Insulation Cover
- ✓ Enclosure DC Light
- ✓ Operations Manual
- ✓ 24 Months / 2000 hours Limited Standby Warranty

**Optional Accessories**

- Main Line CB (3 / 4 Poles – 80% / 100% rated)
- Upsize Alternator
- Anti-condensation Heater
- Voltage Regulation  $\pm 0.5\%$  w/MX321 AVR
- Gas Regulator
- NG / LP Auto Changeover Control System
- Low Gas Pressure Alarm
- Low Coolant Level Alarm
- Oil Pan Heater
- Oil Temperature Display on Controller
- Manual Speed Adjust Rheostat
- Manual Voltage Adjust Rheostat
- Remote Annunciator Panel
- Remote Control & Monitoring Panel
- Advanced SMS Messaging
- Control Panel Heater
- Battery Disconnect Switch
- Battery Heater
- Battery Charger 10/20 Amp
- Shunt Trip / Aux Contacts
- Spring Anti-vibration Isolators
- Automatic Transfer Panel (ATS)
- 5 Years / 2000 hours Limited Comprehensive Warranty

**Mardinly Industrial Power LLC**  
701 Park Way  
Broomall, PA 19008  
P: 610-544-2488  
[sales@mardinly.com](mailto:sales@mardinly.com)

**DISTRIBUTED BY:**